

SIDE THRUSTER

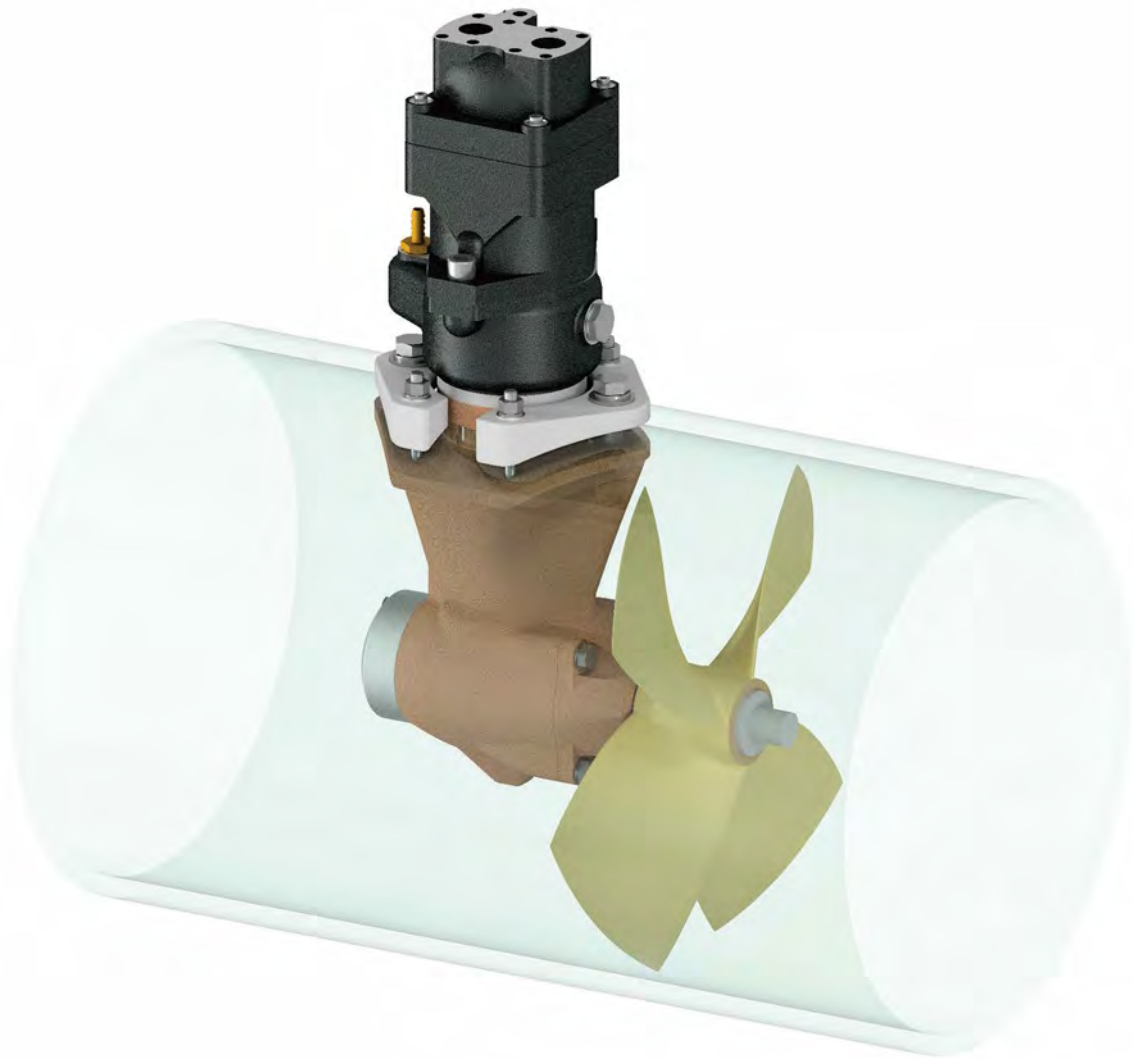

**MARINE TRANSMISSION
HYDRAULIC STEERING SYSTEM
POWER TAKE OFF
SIDE THRUSTER
ELECTRONIC HANDLE UNIT
FLEXIBLE COUPLING_CENTA
HYDRAULIC PUMP, MOTOR
WATER MAKER**



Copyright (C) D-I INDUSTRIAL CO., LTD. All rights reserved.
(52781) 13, Namgang-ro 1367 beon-gil, Jinju-si, Gyeongsangnam-do, Korea
TEL +82-55-760-5520 / FAX +82-55-760-5529 / Email : dicl@d-i.co.kr

Side Thruster

The side thruster is a product that can be mounted on the stern or bow of a vessel to move the vessel left and right. It facilitates the operation of the vessel and can be used conveniently even when berthing the vessel.

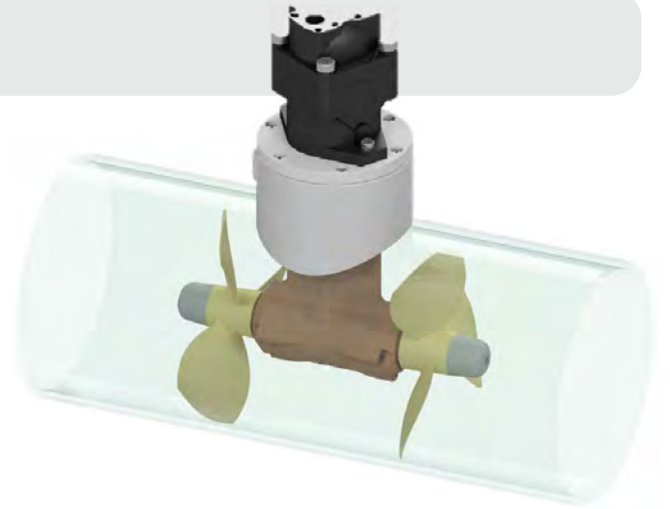

Function

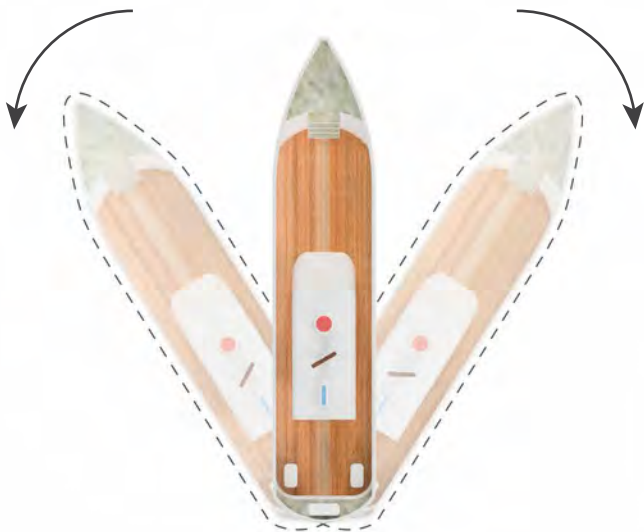

Installed on the bow



Installed on the stern

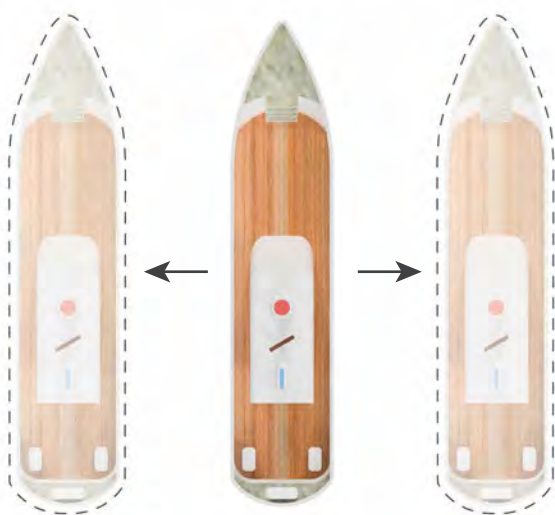

Installed on the bow and stern

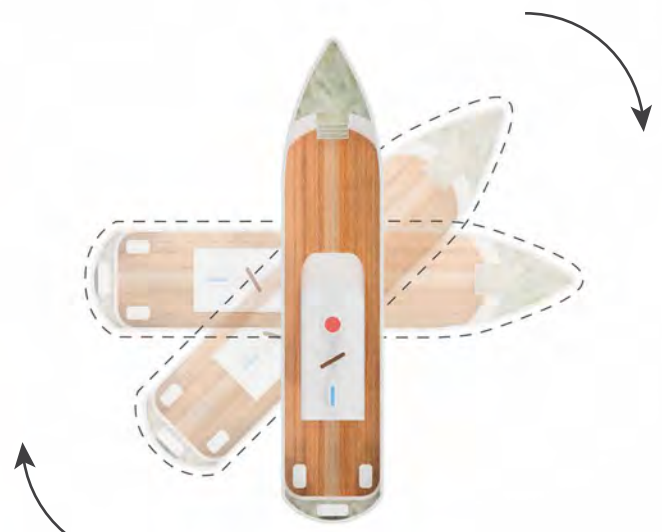

Installed on the bow and stern

Installation

1. Thrust calculation based on the center of turning

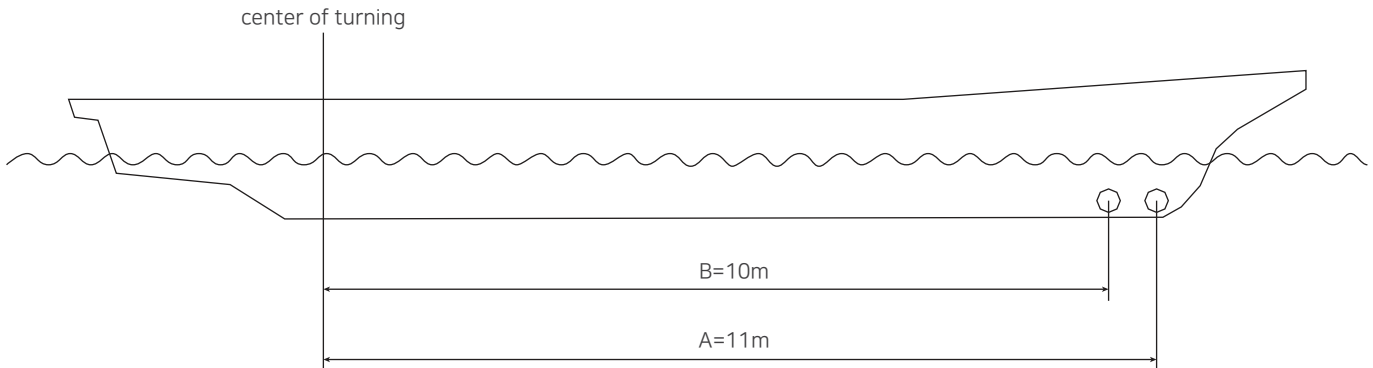

Example :

A: 100kg thrust x 11m leverage = 1100kgm torque to rotate the boat

B: 100kg thrust x 10m leverage = 1000kgm torque to rotate the boat

In position A you will get 10% more thrust to turn the boat around.

2. Recommended installation depth

Generally the top of the tunnel should be a minimum of $1/2 \times$ the tunnel diameter below the waterline. [A]

This is an absolute minimum and we recommend that it is at least $3/4 \times$ tunnel diameter below the waterline. [B]

A really good distance is about $4/4 \times$ tunnel diameter below the waterline. [C]

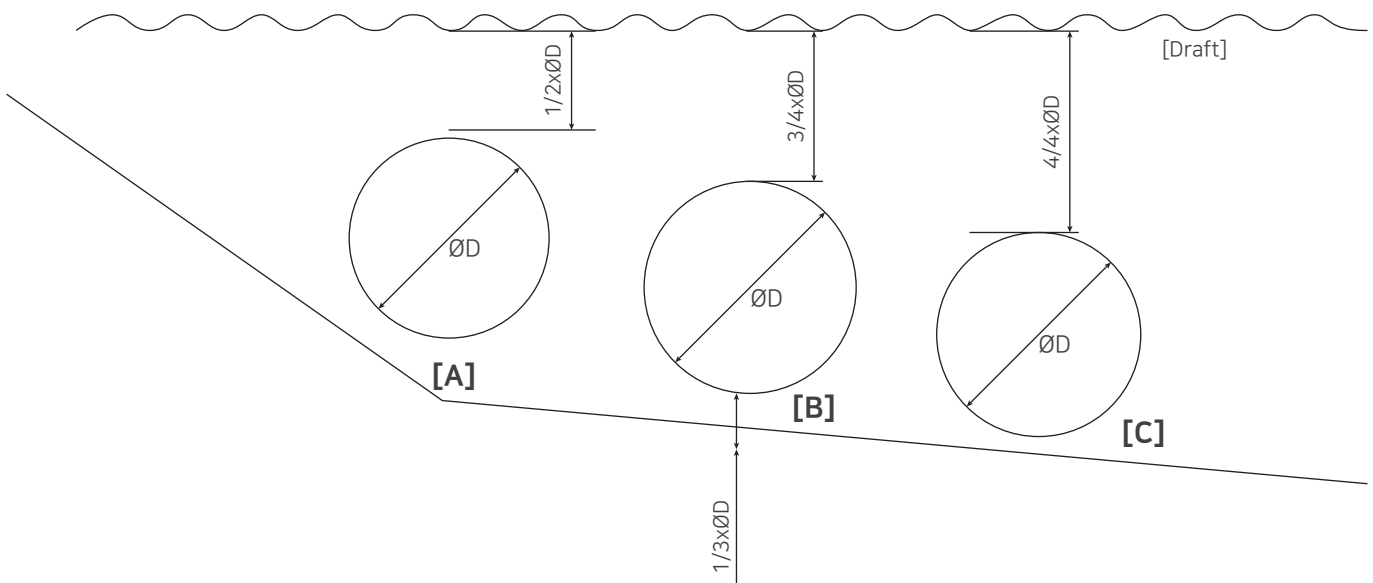

Installation

For the vessels with light weight and low draft, it can be difficult to install a thruster at a location that satisfies the three installation depth conditions. In this case, the tunnel can be installed inclined as shown in the figure below.

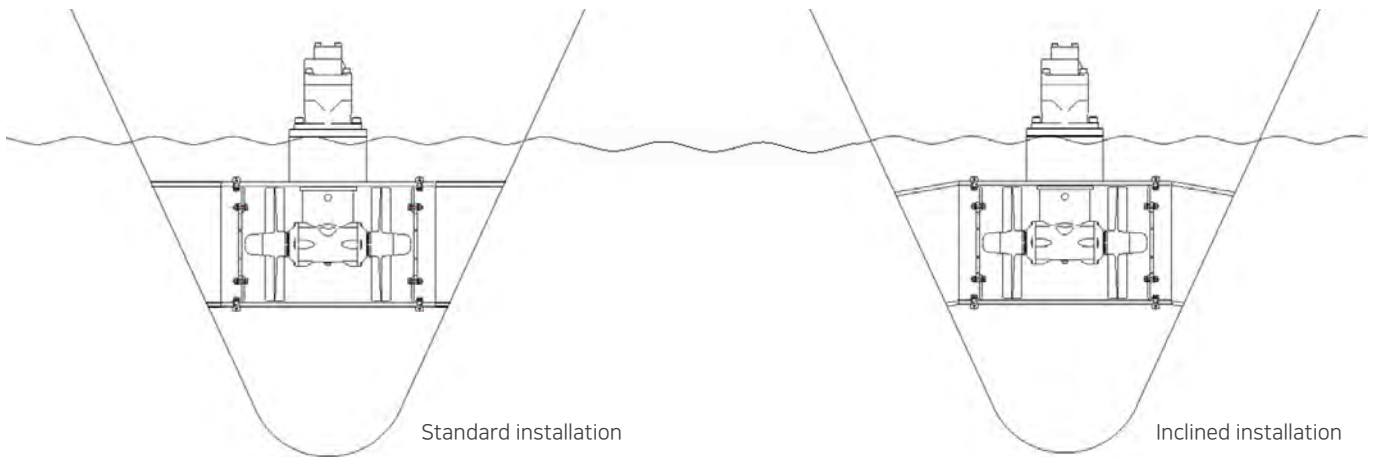

3. Installation tunnel length

- 1) If you want to get the optimal thrust, 2~4 times the inner diameter of the tunnel is most suitable, and if it exceeds 6 times, thrust may be reduced.
- 2) If the tunnel is too long, the frictional resistance increases, which reduces thrust. If the tunnel is too short, cavitation occurs, which may reduce thrust and cause noise.

4. Tunnel ends

Rounded tunnel ends will maximize thrust and minimize noise.

we recommend to round the tunnel connection to the hull-side as much as possible. the optimum rounding has a radius of 10% of the tunnels diameter.

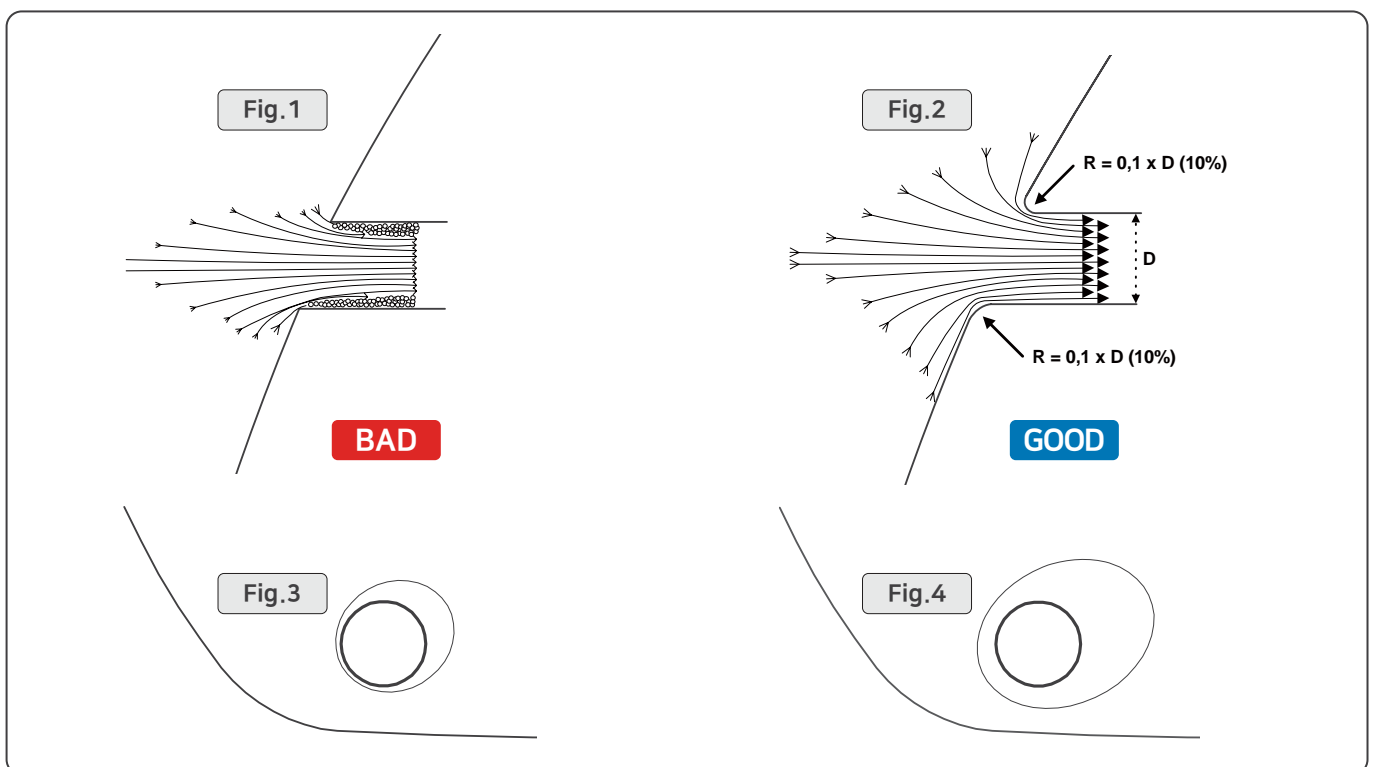

Installation

5. Prevent drag from tunnel

It is recommended to install the tunnel in the shape as shown in the figure below to reduce the decrease in ship speed due to the impact of the water flow on the tunnel during vessel operation.

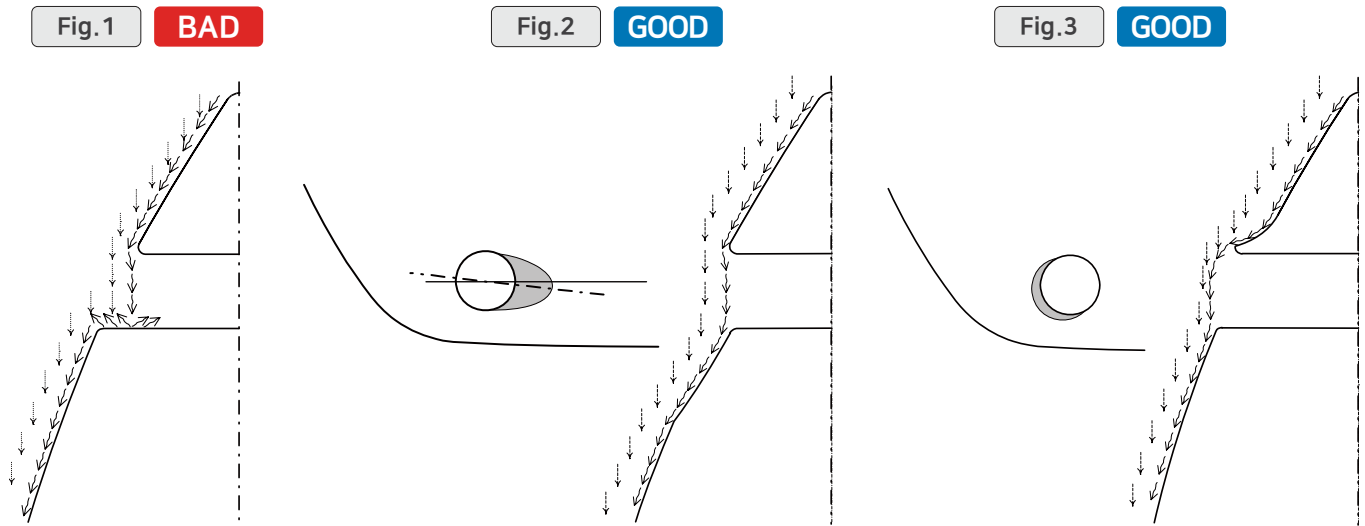
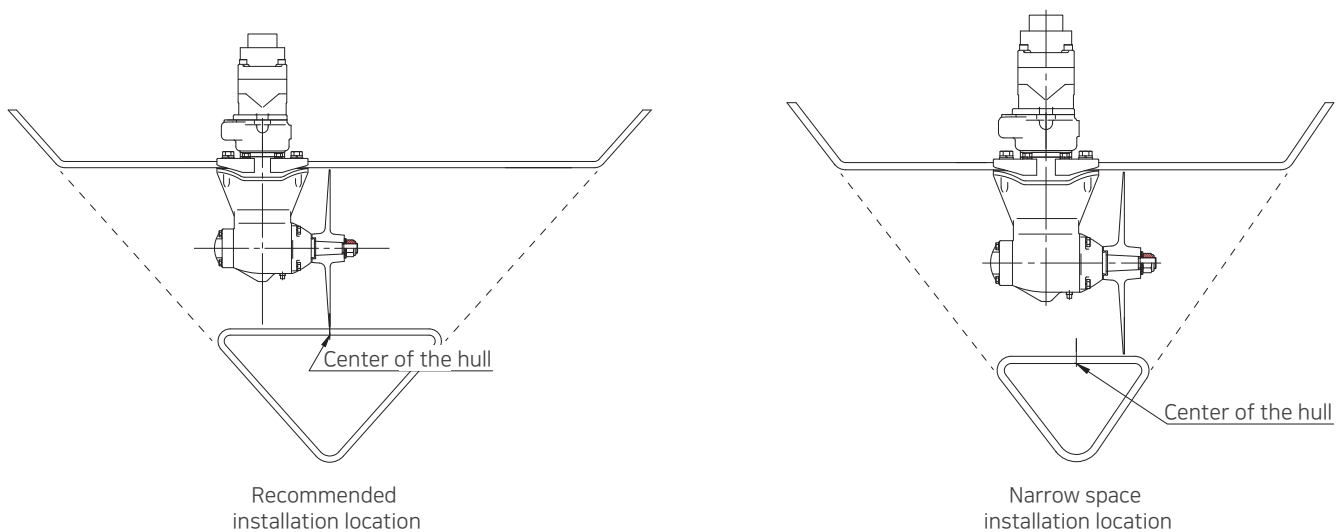

Fig.2 When the installation space is narrow on the hull.

6. Single side thruster (DH400, 500) installation instructions

Single propeller side thrusters (DH500, DH400) can be installed in two ways depending on the size of the hull as shown below.



※ Side thruster model selection guide

1. Please refer to 'Recommended Installation Depth' on page 3 to check the available tunnel inner diameter.
2. please check the dimensions of the side thruster.
3. please check the required horsepower of the side thruster
4. The engine horsepower of the RPM you want to use the side thruster must be equal to or bigger than the required horsepower of the side thruster.
5. In case of AC motor, it should be equal to or bigger than the required horsepower of the side thruster.

Side thruster system configuration | With proportional valve

Model	Thrust Force (kgf)	Tunnel inner diameter (mm)	Part Number				
			Side Thruster	Tunnel (1M)	Drain Filter	Proportinal Valve	Controller
DH300/300C	300	300	57310000	57395381	DF200100A	PV03200GN	PV03201GE
DH330/300C	330	300	57330000	57395381	DF200100A	PV03200GI	PV03201GE
DH395/300C	395	300	57395000	57395381	DF200100A	PV03200GJ	PV03201GE
DH400/400S	400	400	55400000	55400380	DF200100A	PV10000GD	PV03201GE
DH500/400S	500	400	55500000	55400380	DF200100A	PV10000GB	PV03201GE

※ If you need other length of tunnel, please refer to page 11

Side thruster system components with Proportional valve



Side Thruster



Tunnel



Drain Filter



Proportional Valve



Controller

Side thruster system configuration | With solenoid valve

Model	Thrust Force (kgf)	Tunnel inner diameter (mm)	Part Number				
			Side Thruster	Tunnel (1M)	Drain Filter	Solenoid Valve	Controller
DH300/300C	300	300	57310000	57395381	DF200100A	57300900	98684002
DH330/300C	330	300	57330000	57395381	DF200100A	57330900	98684002
DH395/300C	395	300	57395000	57395381	DF200100A	57395900	98684002
DH400/400S	400	400	55400000	55400380	DF200100A	55400900	98684002
DH500/400S	500	400	55500000	55400380	DF200100A	55500900	98684002

※ If you need other length of tunnel, please refer to page 11

Side thruster system components with Solenoid valve



Side Thruster



Tunnel



Drain Filter



Solenoid Valve



Controller

DH300/300C

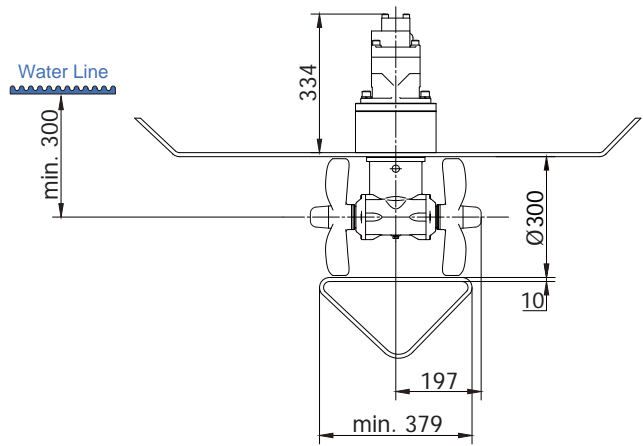

Part number	Model	Thrust Force (kgf)	Input Power (HP)	Rated flow (ℓ/min)	Rated pressure (kg/cm ²)	Tunnel i.d (mm)	Tunnel o.d (mm)	Dry weight (kg)
57310000	DH300/300C	300	25	52.1	220	300	320	61

DH330/300C

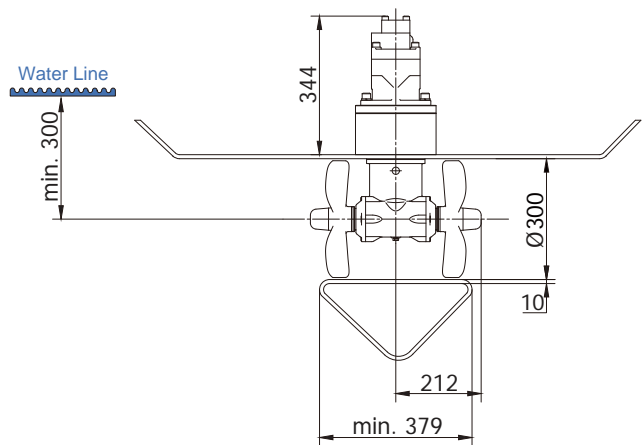

Part number	Model	Thrust Force (kgf)	Input Power (HP)	Rated flow (ℓ/min)	Rated pressure (kg/cm ²)	Tunnel i.d (mm)	Tunnel o.d (mm)	Dry weight (kg)
57330000	DH330/300C	330	31	94	148	300	320	61

DH395/300C

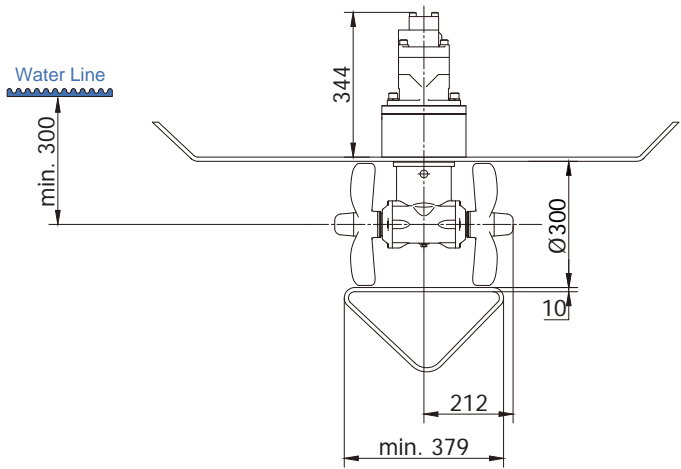

Part number	Model	Thrust Force (kgf)	Input Power (HP)	Rated flow (ℓ/min)	Rated pressure (kg/cm ²)	Tunnel i.d (mm)	Tunnel o.d (mm)	Dry weight (kg)
57395000	DH395/300C	400	42	120	158	300	320	61

DH400/400S

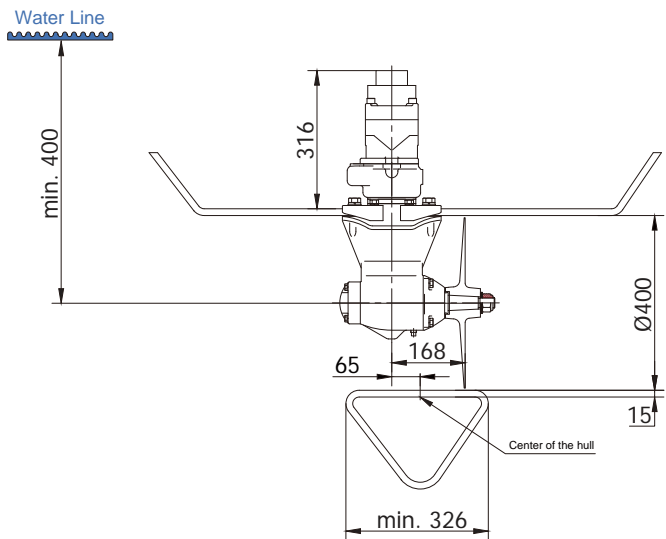

Part number	Model	Thrust Force (kgf)	Input Power (HP)	Rated flow (ℓ/min)	Rated pressure (kg/cm ²)	Tunnel i.d (mm)	Tunnel o.d (mm)	Dry weight (kg)
55400000	DH400/400S	400	45	122.7	169.2	400	431	65

DH500/400S

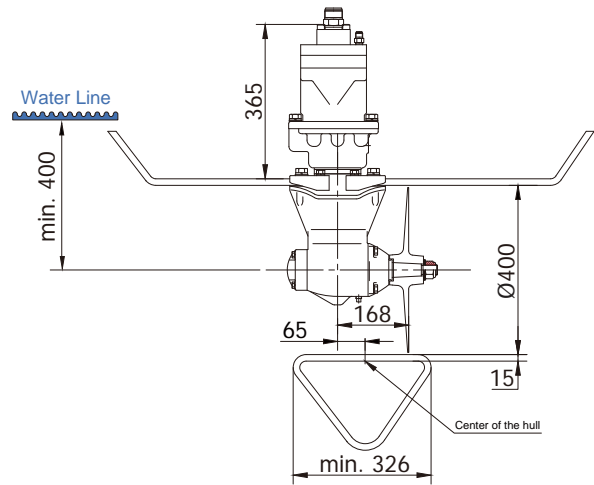

Part number	Model	Thrust Force (kgf)	Input Power (HP)	Rated flow (ℓ/min)	Rated pressure (kg/cm ²)	Tunnel i.d (mm)	Tunnel o.d (mm)	Dry weight (kg)
55500000	DH500/400S	500	57	132.6	192.7	400	431	65

Side Thruster User maintenance guide.

- For DH series, the spare oil reservoir must always be filled with oil(80W90).
[The gear oil needs to be replaced at least every two years_200ml]
※ If oil is not present in the oil reservoir, it is the main cause of damage to gearleg and bearings.
- The inside of the tunnel, propellers, and gearleg must be kept clean to prevent barnacles from growing with anti-pollution paint.
※ Barnacles in tunnels can reduce thruster's propulsion force.
- When checking the ZINC ANODE, replace it if more than half disappeared.
- Before operating side thruster, check for oil leakage in components and piping connections.
- If something wound in propeller such as net, rope, etc. it must be removed before operating side thruster. Otherwise, it may cause damage to propellers and gearleg.

Tunnels

No	Applicable Model	Internal Diameter	Length (meter)	Tunnel Part Number (Propeller Protective Cover not included)			Tunnel Part Number (Propeller Protective Cover included)
				FRP	ALUMINIUM	STEEL	FRP
1	DH300/300C DH330/300C DH395/300C	300	1.0	57395381	57395371	57395391	57395361A
			1.5	57395382	57395372	57395392	57395362A
			2.0	57395383	57395373	57395393	57395363A
			2.5	57395384	-	-	57395364A
2	DH400/400S DH500/400S	400	1.0	55400380	55400371	55400390	55400361A
			1.5	55400381	55400372	55400391	55400362A
			2.0	55400382	55400373	55400392	55400363A



[Tunnel without Propeller Protective Cover]



[Tunnel with Propeller Protective Cover]

Proportional valve



The proportional valve can control the thrust of the side thruster by adjusting the flow rate. It can be controlled using a thruster controller.

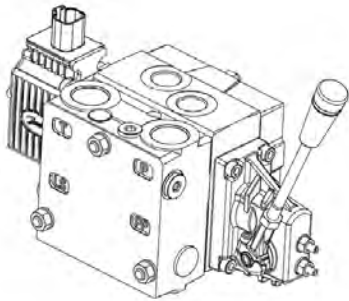

⚠ CAUTION

The drain filter must be installed when installing the proportional control valve. If the drain filter is not installed, it may be excluded from the warranty

Dimensions

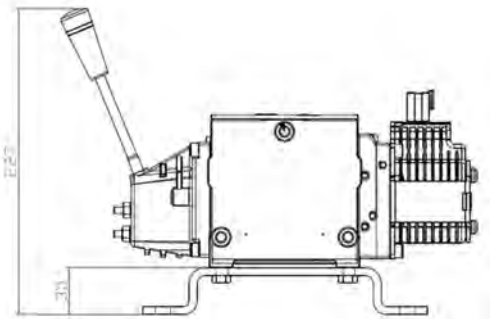
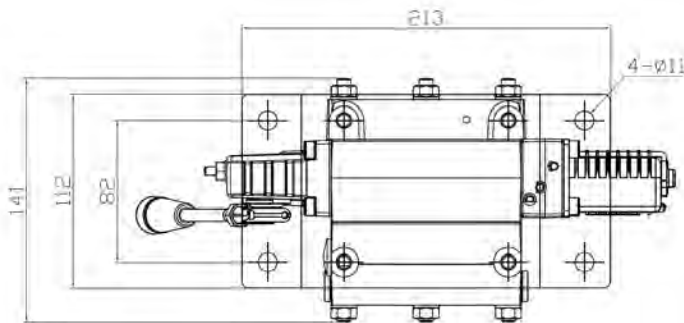

No	Part Number	Model	Flow (ℓ/min)	Rated Pressure (kg/cm ²)	Dry Weight (kg)	Applicable Side Thruster Model	Remark
1	PV03200GN	PVG32N	52	220	18	DH300/300C	
2	PV03200GI	PVG32I	94	148	18	DH330/300C	
3	PV03200GJ	PVG32J	120	158	18	DH395/300C	
4	PV03200GK	PVG100D	132	192	35	DH400/400S	
5	PV03200GL	PVG100B	132	192	35	DH500/400S	

Diagram

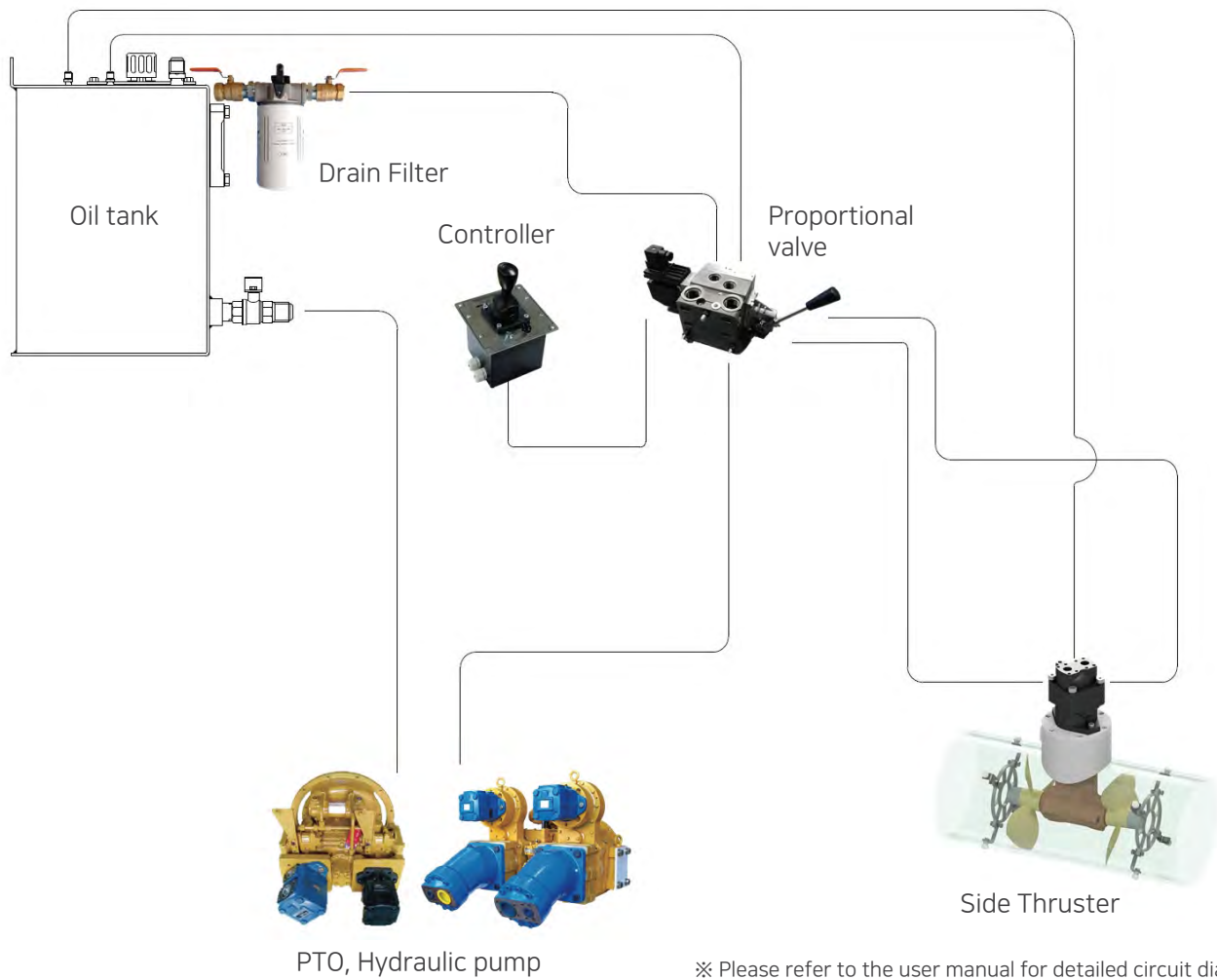

※ Please refer to the user manual for detailed circuit diagram.

Thruster Controller

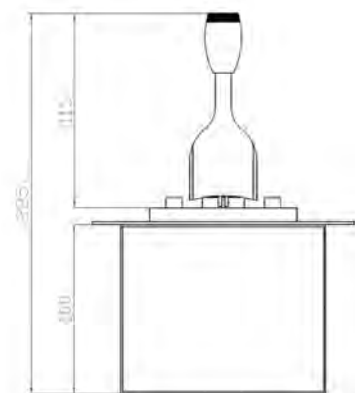
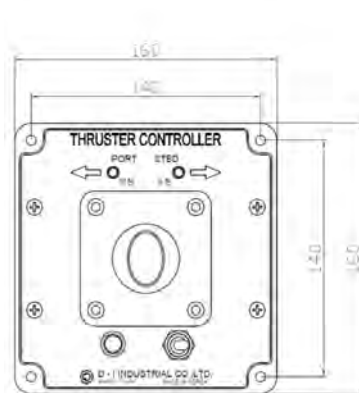

No	Part Number	Model	Applicable Side Thruster Model	Remark
1	PV03201GE	PTC032	DH300, DH330, DH395, DH400, DH500	

Solenoid Valve

Solenoid valve is a product that opens and closes the hydraulic valve by an electrical signal from the thruster controller. It can be installed when you want to use the side thruster only in two ways: ON / OFF.



DSB 300D, 330D, 395D

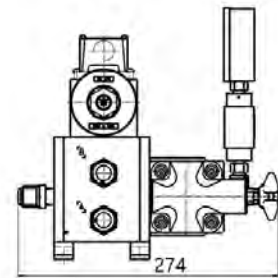
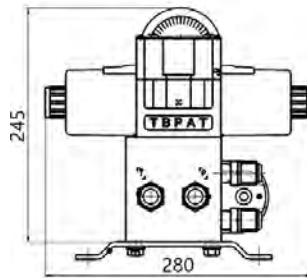

DSB 400D, 500D

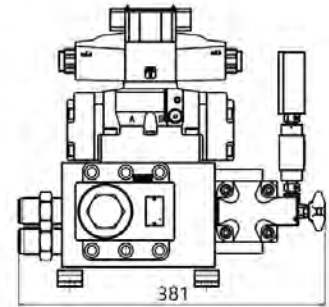
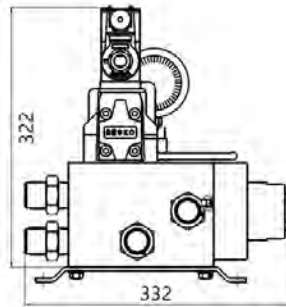

No	Part Number	Model	Flow (ℓ/min)	Rated Pressure (kg/cm ²)	Dry Weight (kg)	Applicable Side Thruster Model	Remark
1	57300900	DSB 300D	52	220	19	DH300/300C	
2	57330900	DSB 330D	94	148	19	DH330/300C	
3	57395900	DSB 395D	120	158	19	DH395/300C	
4	55400900	DSB 400D	122	169	56	DH400/400S	
5	55500900	DSB 500D	132	192	56	DH500/400S	

Diagram

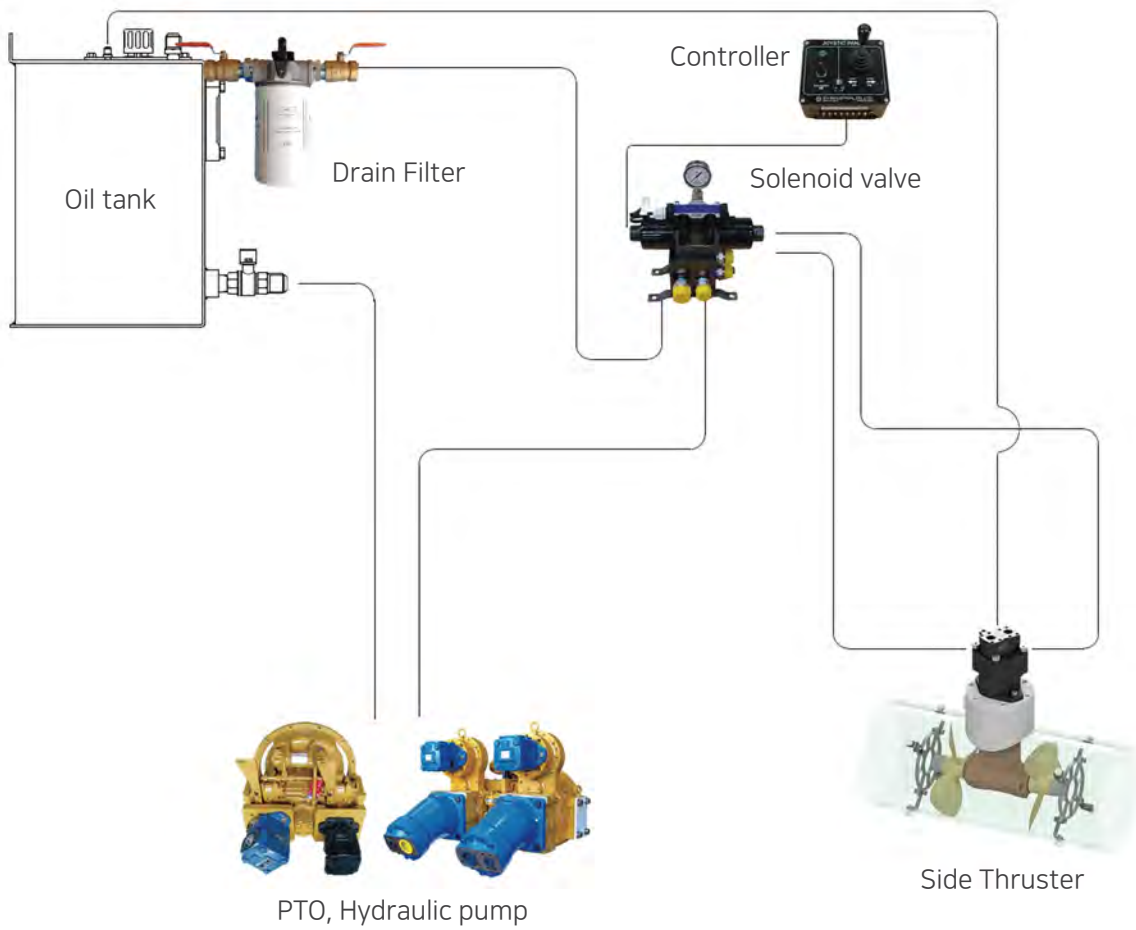

※ Please refer to the user manual for detailed circuit diagram.

Thruster Controller

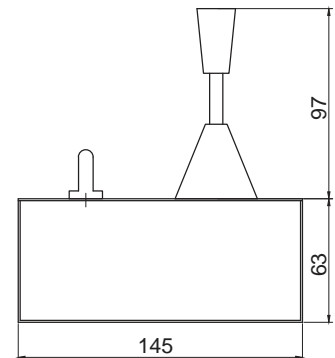
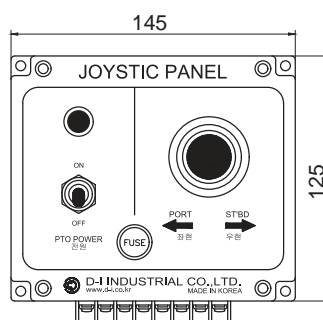

No	Part Number	Model	Applicable Side Thruster Model	Joystick Type	Dry Weight	Remark
1	98684002	DJPS100	All models with Solenoid valve	Return Type	0.9kg	
2	98684102	DJPS200	All models with Solenoid valve	Fixed Type	0.9kg	

Control Panel

PTO + Side thruster control

*For side thruster with solenoid valve only

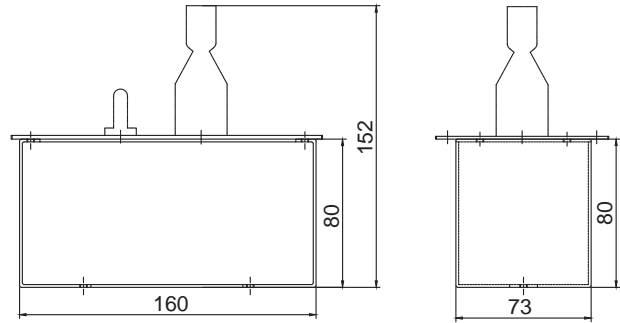
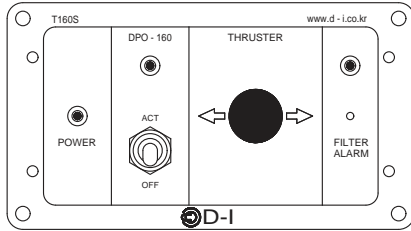

Part Number	Model	Applicable Model	
		PTO	Side Thruster
T160580	T160S	DPO160, 210, 310, 410	All Model

Control Panel

PTO + Side thruster (2 units) control

*For side thruster with solenoid valve only

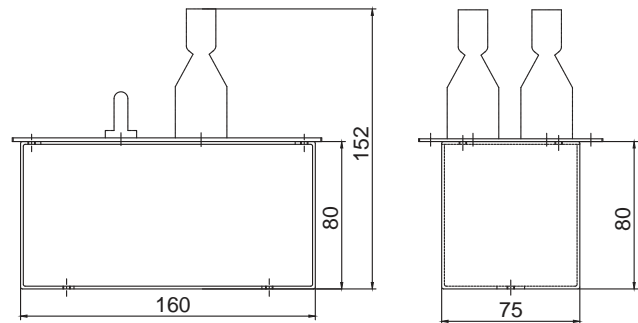
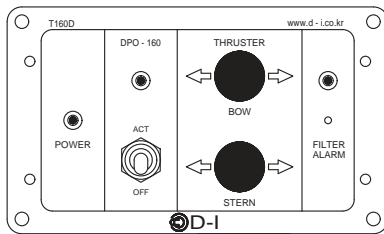

Part Number	Model	Applicable Model	
		PTO	Side Thruster
T16059024	T160D	DPO160, 210, 310, 410	All Model

Control Panel

DPO087 + Side thruster control

*For side thruster with solenoid valve only

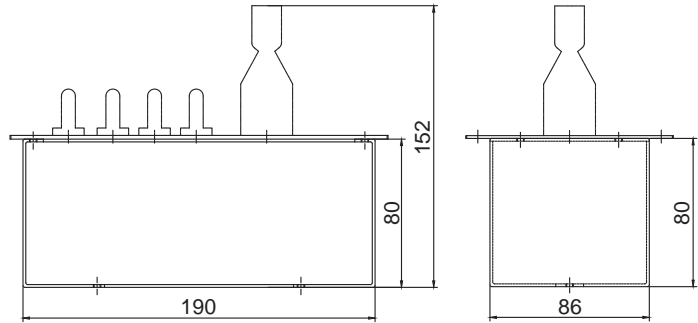
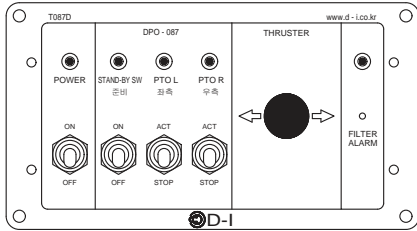

Part Number	Model	Applicable Model	
		PTO	Side Thruster
T087680	T087S	DPO087	All Model

Control Panel

DPO087 + Side thruster (2 units) control

*For side thruster with solenoid valve only

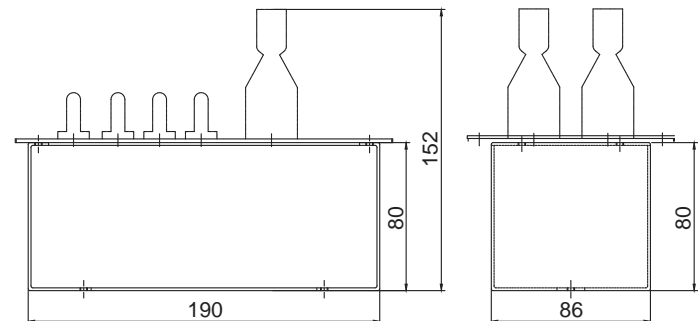
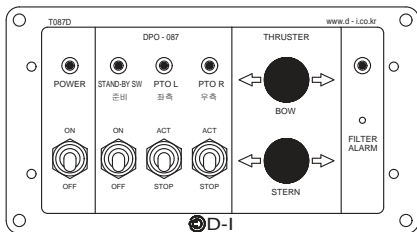

Part Number	Model	Applicable Model	
		PTO	Side Thruster
T087690	T087D	DPO087	All Model

Control Panel

DPO167 + Side thruster control

*For side thruster with solenoid valve only

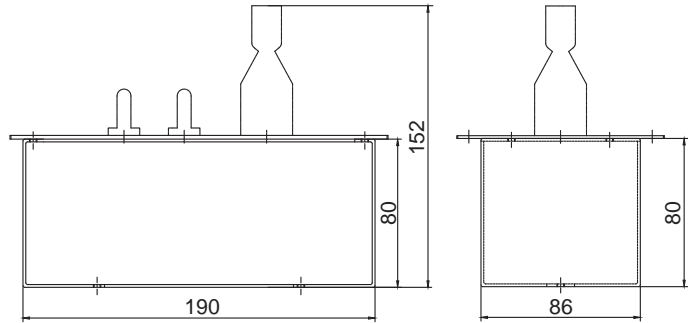
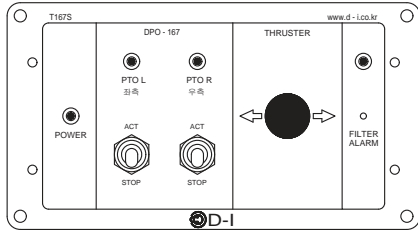

Part Number	Model	Applicable Model	
		PTO	Side Thruster
T167570	T167S	DPO167	All Model

Control Panel

DPO167 + Side thruster (2 units) control

*For side thruster with solenoid valve only

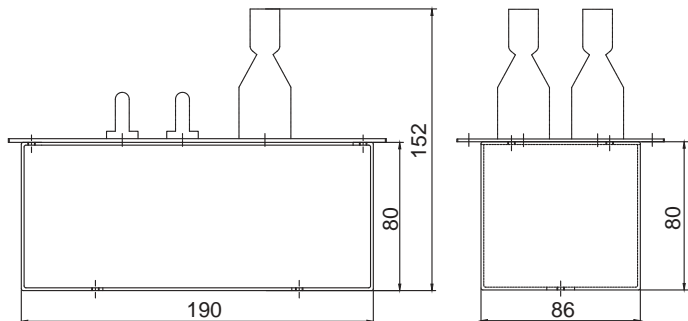
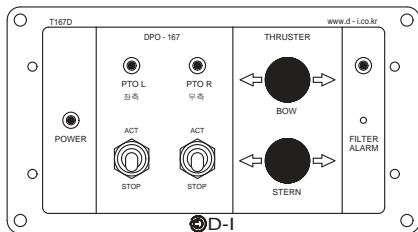

Part Number	Model	Applicable Model	
		PTO	Side Thruster
T16759026	T167D	DPO167	All Model

Single Control Panel

Proportional valve control

※ Suitable Item for customers with limited space for thruster controller installation.

Part Number	Model
PV900103	PTC-001

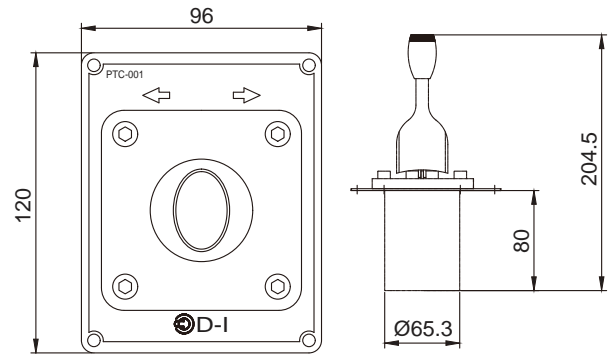

Twin Control Panel

2 units Proportional valve control (Horizontal type)

※ Suitable Item for customers with limited space for thruster controller installation.

Part Number	Model
PV900105	PTC-001W

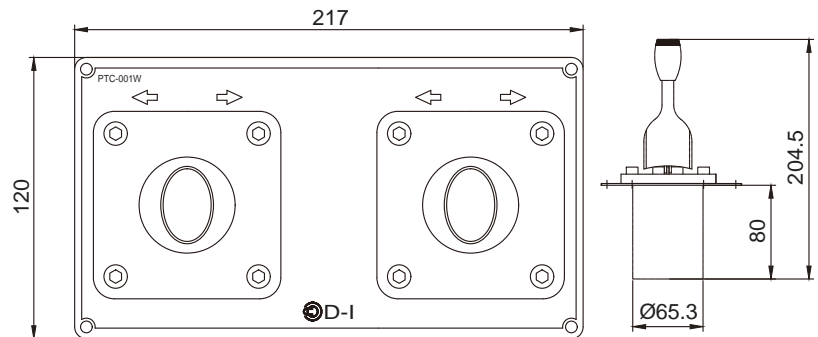

Twin Control Panel

2 units Proportional valve control (Vertical type)

※ Suitable Item for customers with limited space for thruster controller installation.

Part Number	Model
PV900107	PTC-001L

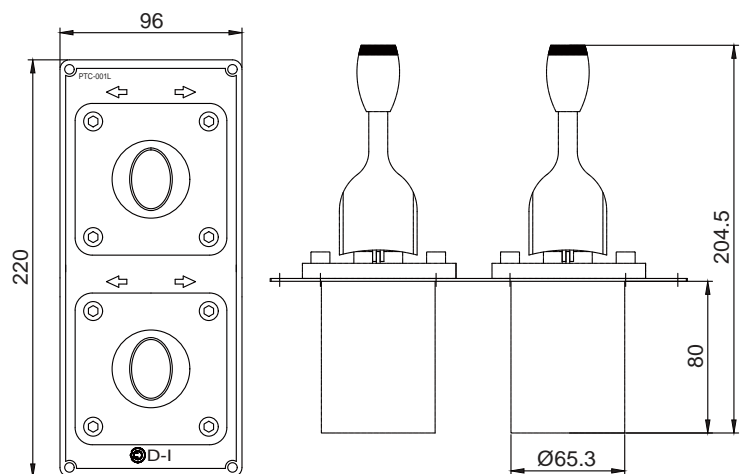

Oil Tank

60 ℓ

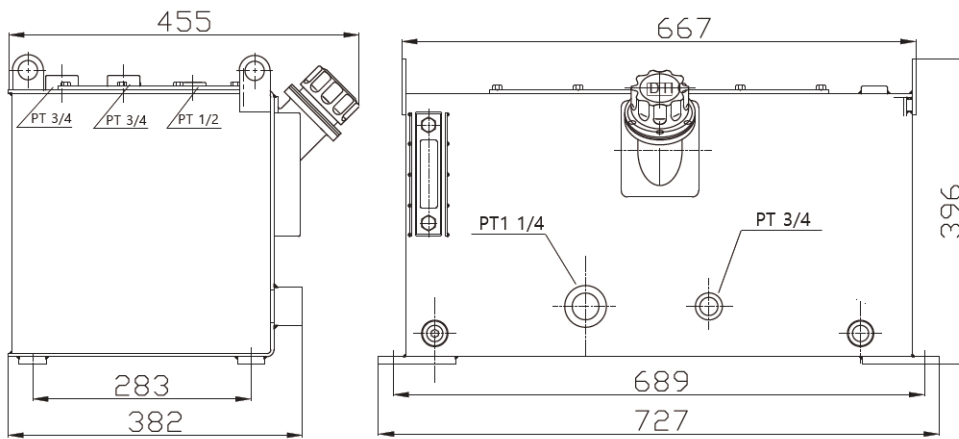

Part Number	Model	Capacity	Remark
98500600AS	DOT 60	60L	

Oil Tank

100 ℓ (Front Suction Port)

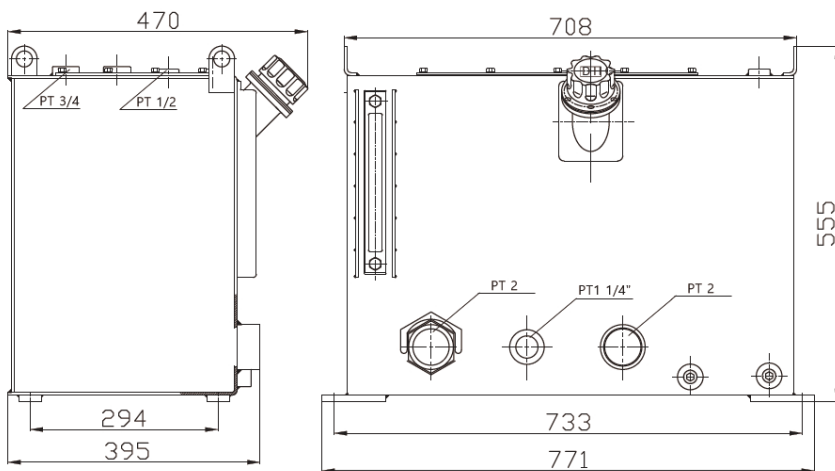

Part Number	Model	Capacity	Remark
98500400AS	DOT 100	100L	Front suction port type

Oil Tank

100 ℓ (Side Suction Port)

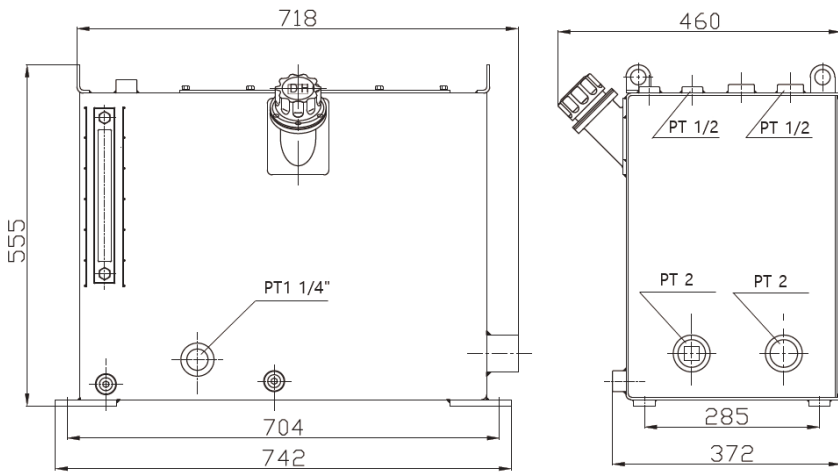

Part Number	Model	Capacity	Remark
98500100AS	DOTL 100	100L	Side suction port type

Oil Tank

200 ℓ

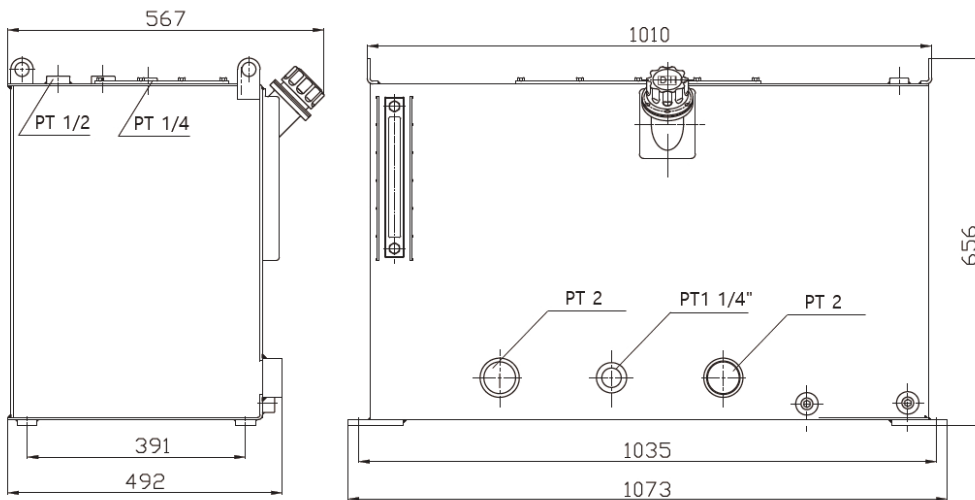

Part Number	Model	Capacity	Remark
98500900AS	DOT 200	200L	

Required pump capacity for side thrusters according to the PTO model

Engine 700 rpm

(cc/rev)

No	Model	PTO model (Ratio)				
		DPO087		DPO160	DPO210	DPO310
		(1:1)	(0.849:1)	(1:1)	(1:1)	(1:1)
1	DH300/300C	82	69	82	82	82
2	DH330/300C	148	125	148	148	148
3	DH395/300C	-	160	189	189	189
4	DH400/400S	-	163	192	192	192
5	DH500/400S	-	-	208	208	208

※ For DH300/300C, please use HT6CM pump.

Engine 700 rpm

(cc/rev)

No	Model	PTO model (Ratio)						
		DPO167				DPO410		
		(0.95:1)	(0.83:1)	(0.72:1)	(0.66:1)	(0.9787:1)	(0.7692:1)	(0.6607:1)
1	DH300/300C	78	68	59	54	80	63	54
2	DH330/300C	140	123	106	97	145	114	98
3	DH395/300C	179	157	136	124	185	145	125
4	DH400/400S	182	159	138	127	188	147	127
5	DH500/400S	198	173	150	138	204	160	138

※ For DH300/300C, please use HT6CM pump.



DPO087



DPO160,210,310



DPO167



DPO410

Hydraulic Vane Pump

(cc/rev)

No	Part Number	Model	Capacity (cc/rev)	Max Pressure (bar)	Remark
1	98475610T	HT6CM-022-3R01-M0	70	240	
2	98475620T	HT6CM-025-3R01-M0	79	240	
3	98475630T	HT6CM-028-3R01-M0	89	240	
4	98473200T	25HVQ-14AM-11C-R	45	206	
5	98473201T	25HVQ-17AM-11C-R	55	206	
6	98473210T	25HVQ-21AM-11C-R	67	206	
7	98473300T	35HVQ-25AM-11C-R	81	206	
8	98473310T	35HVQ-30AM-11C-R	97	206	
9	98473320T	35HVQ-35AM-11C-R	112	206	
10	98473330T	35HVQ-38AM-11C-R	121	206	
11	98475200T	HT6DM-042-3R01-M0	136	240	
12	98475210T	HT6DM-045-3R01-M0	145	240	
13	98475410T	HT6EM-050-3R01-M0	158	206	
14	98475340T	KT6EMY-057-3R01-A1	180	240	
15	98475350T	KT6EMY-062-3R00-A1	196	240	
16	98475360T	KT6EMY-072-3R00-A1	227	240	

- ※ Please use a pump with higher pressure than the Side thruster's one
- ※ When ordering a pump without flanges, please order by model name.



Flanges

Hydraulic Piston Pump

No	Part Number	Model	Part Name	Max Pressure (bar)	Remark
1	98492500G	TBP140S	Piston Pump	140cc/rev	
2	98492600G	TBP160S	Piston Pump	160cc/rev	
3	98492700G	TBP180S	Piston Pump	180cc/rev	
4	98492800G	TBP200S	Piston Pump	200cc/rev	



Flanges

Pump size selection table

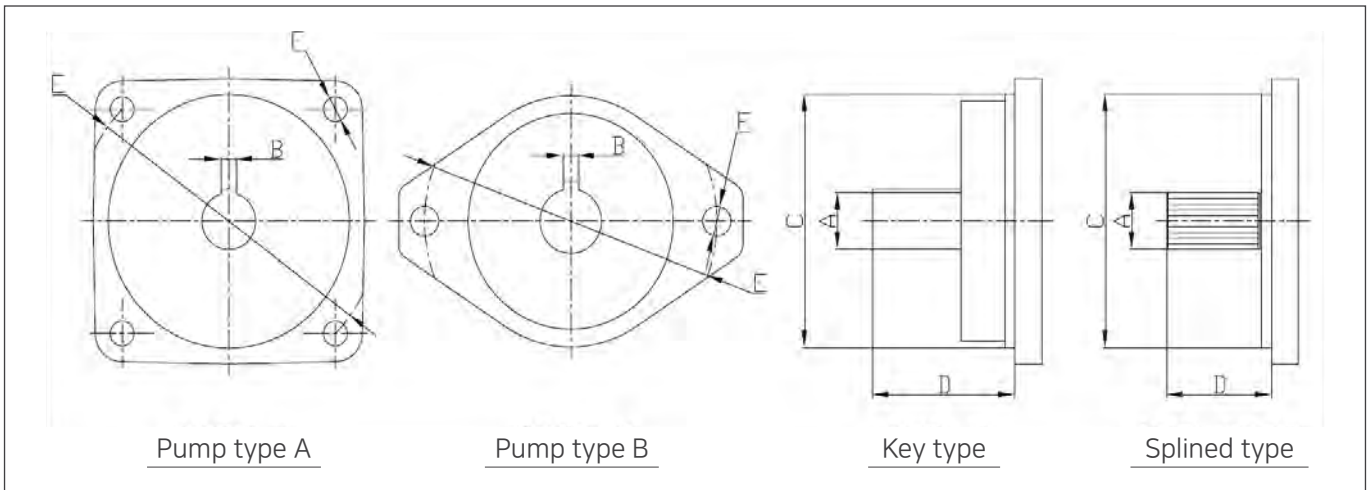

Table 1 ▼

No	Shaft type	A	B	C	D	E	F	Number of Teeth	Pump Model
1	Splined	DP16/32 13T	-	Ø101.6	41.1	Ø146	2-Ø14.2	13	20HVQ
2	Splined	DP16/32 13T	-	Ø101.6	44.5	Ø146	2-Ø14.2	13	25HVQ
3	Splined	DP16/32 13T	-	Ø101.6	40.7	Ø146	2-Ø14.2	13	HT6CM
4	Splined	DP12/24 14T	-	Ø127	58.7	Ø181	2-Ø17.5	14	35HVQ
5	Splined	DP12/24 14T	-	Ø127	61.9	Ø181	2-Ø17.5	14	45HVQ
6	Splined	DP12/24 14T	-	Ø127	55.2	Ø181	2-Ø17.5	14	HT6DM, HT6DCM
7	Splined	DP12/24 14T	-	Ø127	55.9	Ø181	2-Ø17.5	14	HT6EM, HT6ED
8	Splined	M25 17T	-	Ø180	93	Ø250	4-Ø22	17	TBP140S, TBP160S, TBP180S, TBP200S
9	Standard supply specification								

※ If there is no pump of the applicable size in the table above, please select the standard supply specification.(No.9)

Pump attachment plate selection table

※ Refer to Table 1 above and select the applicable pump model from the table below.
Please order a pump attachment plate for your PTO and pump model.

No	Pump Model	PTO Model and Part Number				
		DPO087	DPO160	DPO210, 310	DPO167	DPO410
1	20HVQ	AS_T087216B	AS_T160617	-	-	-
2	25HVQ, HT6CM	AS_T087216B	AS_T160617	-	-	AS_T410622
3	35HVQ, 45HVQ	AS_T087216E	AS_T160616	AS_T310621	AS_T410621_004	AS_T410621_004
4	HT6DM, HT6DCM	AS_T087216E	AS_T160616	AS_T310621	AS_T410621_004	AS_T410621_004
5	HT6EM, HT6ED	-	AS_T160616	-	-	-
6	TBP140S, 160S, 180S, 200S	-	-	-	AS_T410657	AS_T410657
7	Standard supply specification	AS_T087216	AS_T160615	AS_T310615	AS_T410615_002	AS_T410615_002

DPO087



It is attached to the pulley of engine or bell housing and gets 2 output shafts each to drive an independent clutch. There are two types of connection methods. One is pump mount type and the other is shaft type.

Model	Ratio	Max input rpm (rpm)	Input capacity		Clutch Type	Number of output	Output torque (kgf.m) (Left/Right)	Max output rpm (rpm)	Dry weight (kg)	Bell Housing (SAE)
			HP	kw						
DPO087	0.849	3000	385	287	2 Clutch	2	51/51	3000	123	1,2,3 Pulley
	1:1	3000	454	338	2 Clutch	2	55/55	3000	124	1,2,3 Pulley

DPO167



It is attached to the pulley of engine or bell housing and gets 2 output shafts each to drive an independent clutch. The hydraulic pump is a direct connection method.

※ DPO167 has basically 2 outputs, and 3 to 4 outputs can be applied by adding a gearbox.

Model	Ratio	Max input rpm (rpm)	Input capacity		Clutch Type	Number of output	Output torque (kgf.m) (Left/Right)	Max output rpm (rpm)	Dry weight (kg)	Bell Housing (SAE)
			HP	kw						
DPO167	0.6603	1981	872	650	2 Clutch	2~4	160/160	3000	380	1,2,Pulley
	0.7255	2177	959	715	2 Clutch	2~4		3000	380	1,2,Pulley
	0.8333	2500	1101	821	2 Clutch	2~4		3000	382	1,2,Pulley
	0.9556	2867	1263	942	2 Clutch	2~4		3000	384	1,2,Pulley
	1.3784	3000	1322	985	2 Clutch	2~4		2176	392	1,2,Pulley
	1.5143	3000	1322	985	2 Clutch	2~4		1981	394	1,2,Pulley

DHD500 / 400SRR / Stern type thruster

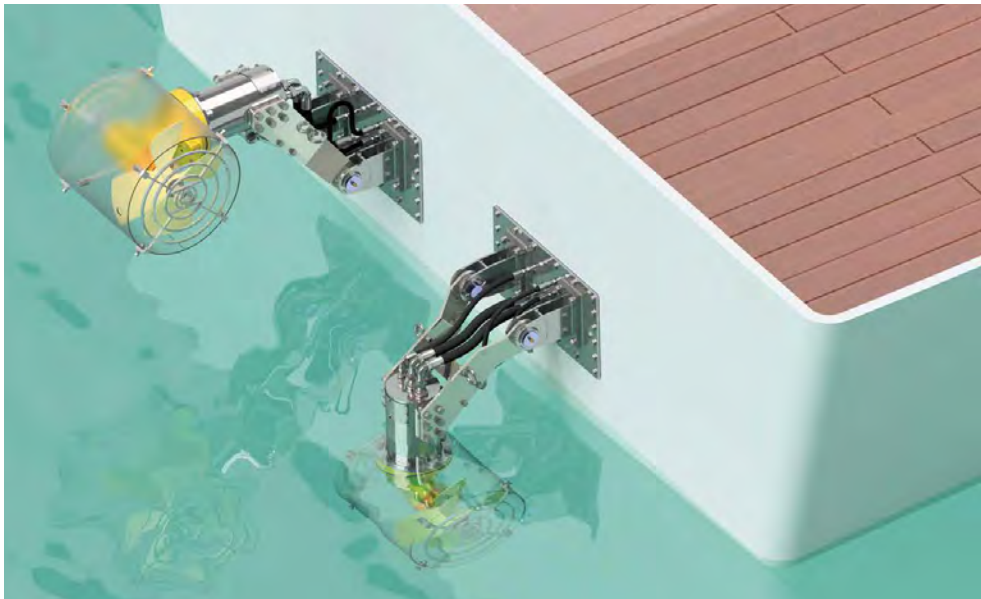

※ Stern type thruster advantages

1. Maintain ship efficiency by simply attaching to the hull without the need for tunnel construction
2. Big turning force due to the installation of the stern end
3. Easy maintenance and reduced maintenance cost with external installation type
4. High durability due to motor direct connection type

Part number	Model	Thrust (kgf)	Required horsepower (HP)	Rated Flow (ℓ/min)	Rated pressure (kg/cm ²)	Tunnel I.D (mm)	Tunnel O.D (mm)	Dry weight (kg)
55520000	DHD500/400SRR	500	49	122	169.2	400	408	127

Dimension

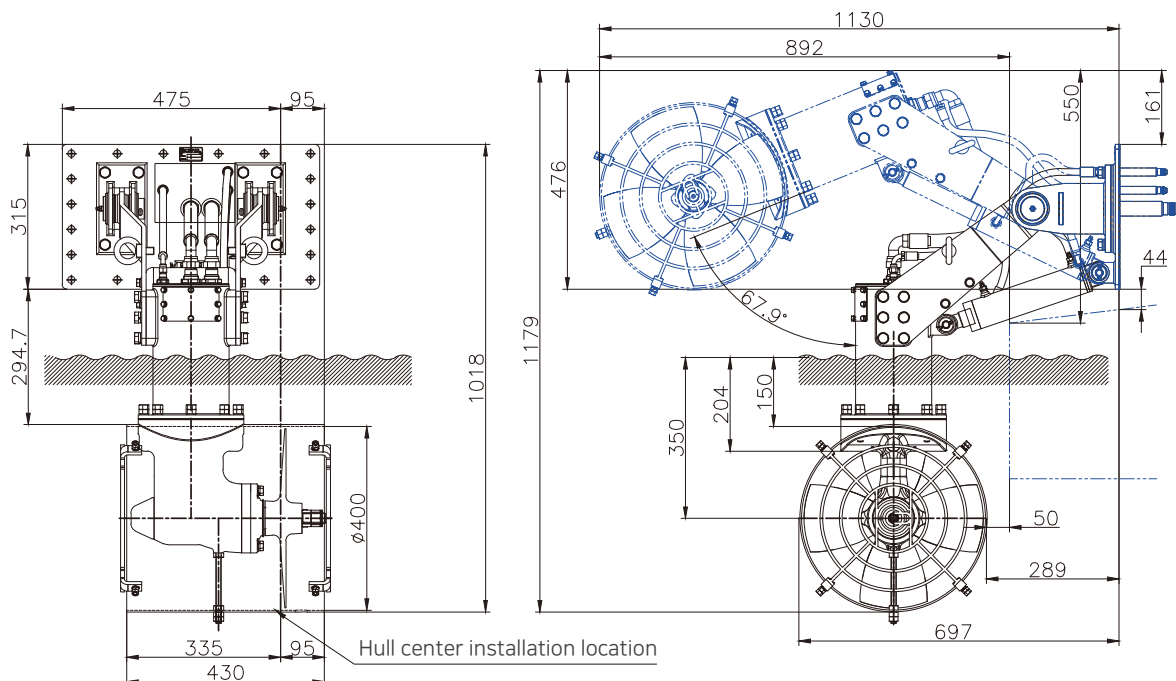

Diagram

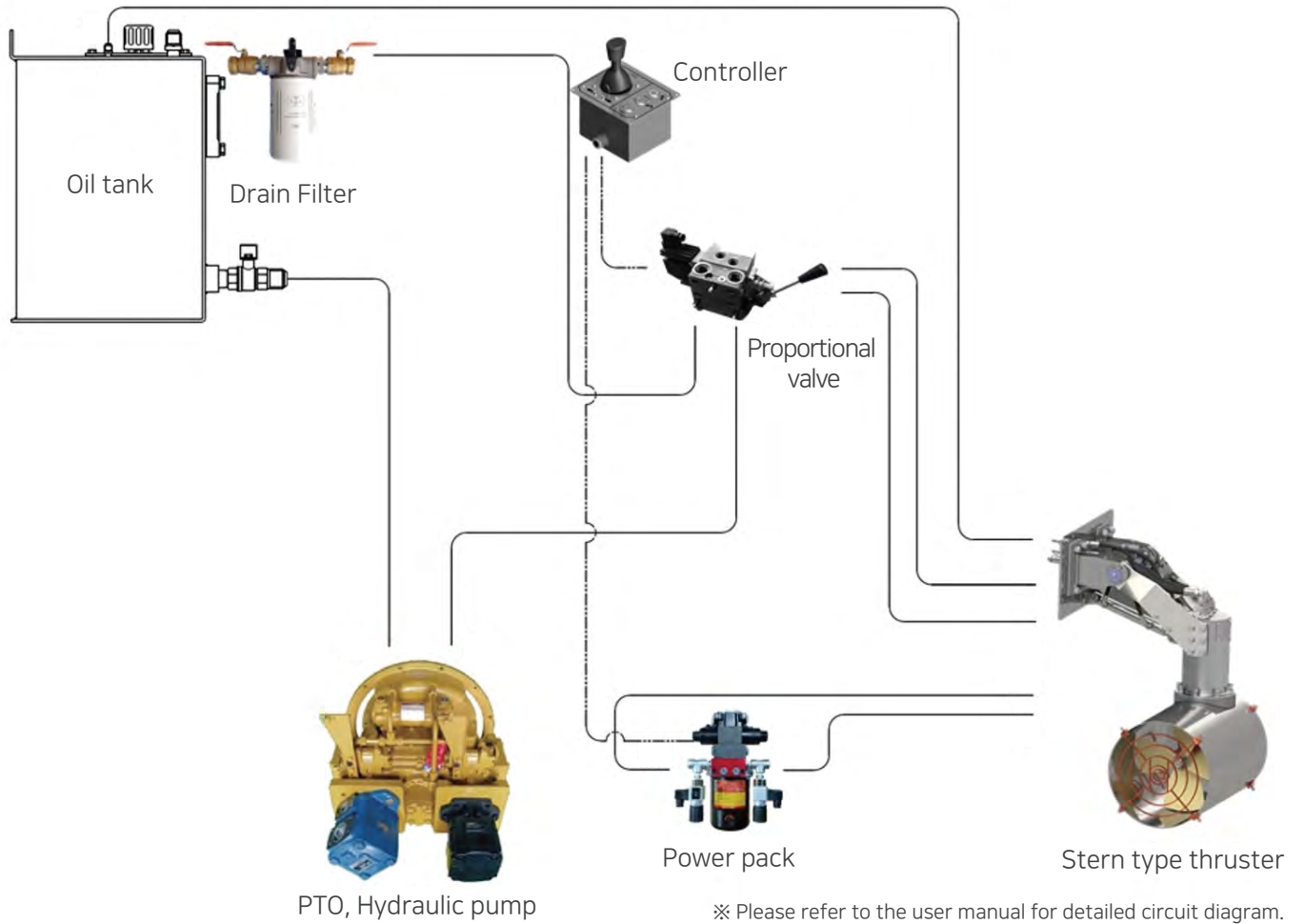

Stern type thruster package components



Components	Stern type thruster	Power pack	Proportional valve	Drain filter	Controller
Model	DHD500/400SRR	DEP-002D2	PVG32K	DLF-200A	PTC-002B
Part number	55520000	MP55520001	PV03200GK	DF200100A	55520400

Mini power pack

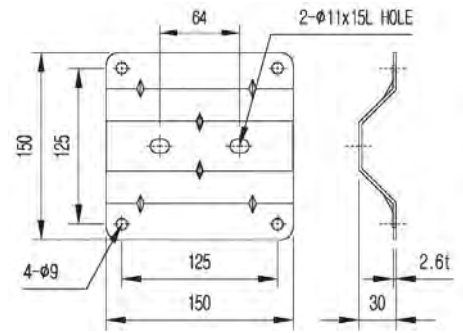
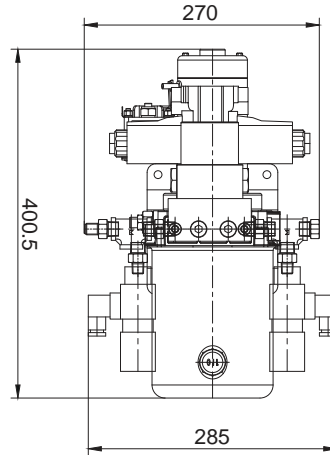

Bracket

Part Number	Model	Applicable thruster model	Remark
MP5520001	DHD500/400SRR	DHD500/400SSTRR	

Stern type thruster controller

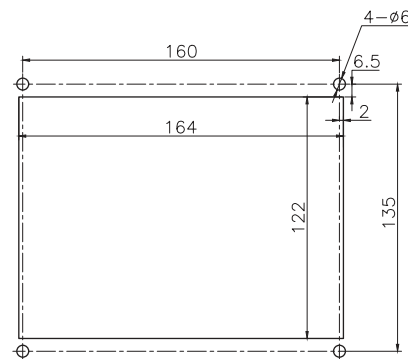
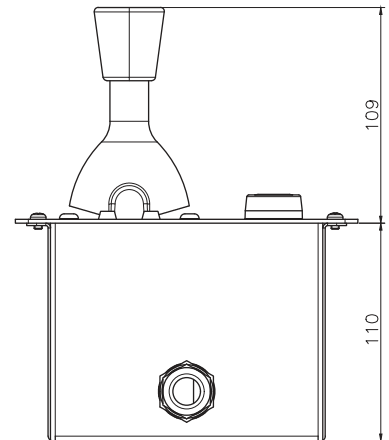
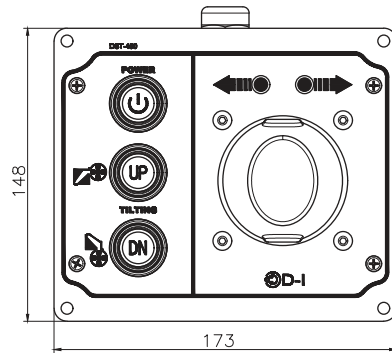

Part Number	Model	Applicable thruster model	Remark
5552040038	PTC-002B	DHD500/400SRR	