

# M14 UI VEHICLE ENGINES

## FACTS

- Rated power: 95-120 kW
- Torque: up to 340 Nm @ 1800 rpm
- Dry weight: 180-240 kg

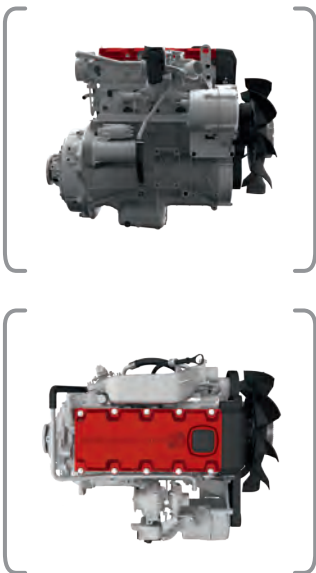
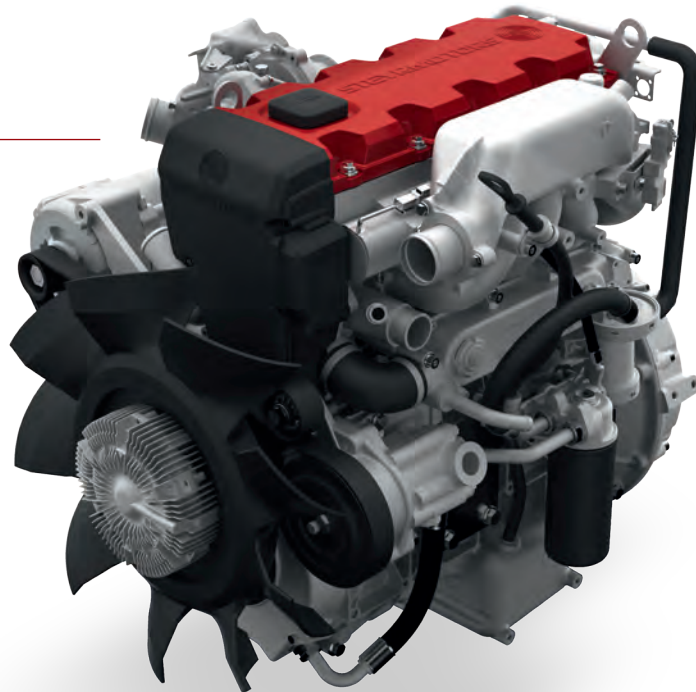

The M14 UI is STEYR MOTORS' 4-cylinder diesel engine with proven, reliable unit injector technology. A range of models is available for our customer's use as provided or as base models for customizing to individual requirements.

## MAIN FEATURES

- Monoblock design with excellent water cooling
- Variable turbocharger, intercooled
- Operational temperature range from -32 °C to +49 °C
- Multifuel capable: F-34/F-35/F-54/F-63/F-65/JP-8/JET A1/EN 590
- High ICE efficiency for higher range and/or lower fuel consumption
- Small packaging dimensions, low weight
- High robustness and durability
- Outstanding performance



See more applications on our website or contact us for further references.

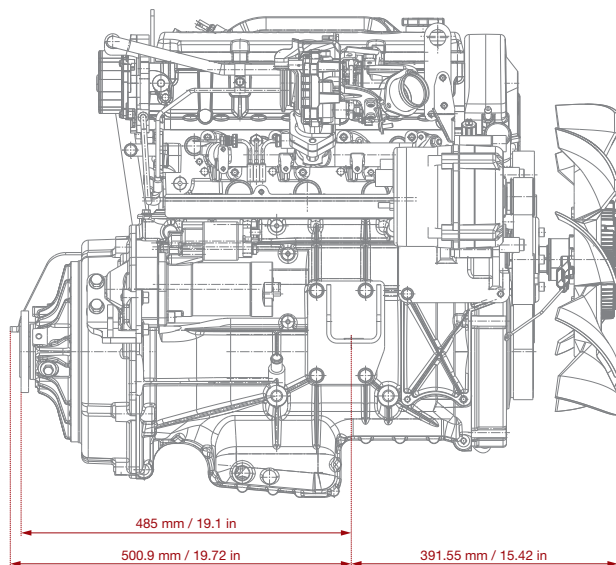
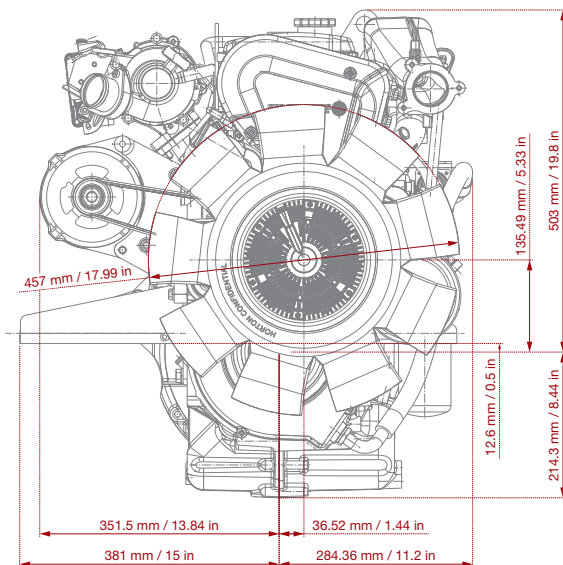

	<b>M14 VTI</b> 95 KW MODEL	<b>M14 VTI</b> 110 KW MODEL	<b>M14 VTI</b> 120 KW MODEL
<b>COMBUSTION SYSTEM</b>	Direct Injection Diesel	Direct Injection Diesel	Direct Injection Diesel
<b>DISPLACEMENT (LT)</b>	2.1	2.1	2.1
<b>BORE (MM)</b>	85	85	85
<b>STROKE (MM)</b>	94	94	94
<b>CHARGING SYSTEM</b>	Turbocharged, intercooled	Turbocharged, intercooled	Turbocharged, intercooled
<b>RATED POWER (KW/HP)*</b>	95/129	110/148	120/163
<b>RATED SPEED (RPM)</b>	3800	3800	3800
<b>MAX. TORQUE (NM @ RPM)*</b>	295 @ 2000	320 @ 1800	340 @ 1800
<b>MIN. FUEL CONSUMPTION (G/KWH)*</b>	208	204	204
<b>DRY WEIGHT (KG)</b>	179	182	220

\* based on Diesel EN 590

#### OVERALL CHARACTERISTICS

- 4-stroke, turbocharged, intercooled
- 3 basic models, distinguished by power and torque
- Perfectly suited for customizing to your specific requirements